

FEKA 600 SEWAGE PUMPS



DRAINAGE WASTE WATER FOR DOMESTIC USE

Pump body, impeller, cap and suction grid in technopolymer. Motor, rotor shaft and screws in stainless steel. Triple O-ring seal interposed with an oil precombustion chamber. Continuous duty submersible asynchronous motor. Stator fitted in an airtight stainless steel casing. Rotor mounted on oversized, greased-for-life ball bearings. Built-in thermal and current overload protection and a capacitor permanently on in the single-phase version. For the protection of the three-phase motor it is advisable to use a suitable overload protection complying with the regulations in force. Supplied with standard power cables for the single-phase version:
 5 metres HO5RN-F cable for: FEKA 600 M-A.
 10 metres HO7RN-F cable for: FEKA 600 M-NA.
 Standard cables supplied for the three-phase version:
 5 metres of HO7RN-F cable. For the single phase the standard is a SCHUKO plug EEC VII.

For special version available with special stainless steel motor shaft.

Operating range: from 1 to 16 m³/h with head up to 10.2 metres.

Liquid temperature range: from 0°C to +35°C for domestic use.

Pumped liquid characteristics:

FEKA sewage water from septic tanks.

Granulometric passage through the suction grid:

FEKA 600 25 mm.

Min. suction depth:

FEKA 600 A 175 mm.

FEKA 600 NA 38 mm.

Maximum immersion depth: 7 metres.

Maximum dry running time: 1 minute.

Protection level: IP 68.

Insulation class: F.

TECHNICAL DATA

MODEL	CODE	ELECTRICAL DATA						
		VOLTAGE 50 HZ	P1 MAX kW	P2 NOMINAL		In A	CAPACITOR	
				kW	HP		µF	Vc
FEKA 600 M-A	103022214	1X220-240 V~	0,94	0,55	0,75	4,3	14	450
FEKA 600 M-NA	103022384	1X220-240 V~	1	0,55	0,75	4,3	-	-
FEKA 600 T-NA	103000054	3X400 V~	1	0,55	0,75	1,7	-	-

M - T = Available in single-phase (M) and three-phase (T) version

SPECIAL VERSION with a special stainless steel motor shaft

MODEL	CODE	ELECTRICAL DATA						
		VOLTAGE 50 HZ	P1 MAX kW	P2 NOMINAL		In A	CAPACITOR	
				kW	HP		µF	Vc
FEKA 600 M-A - SV	103002774	1X220-240 V~	0,94	0,55	0,75	4,3	14	450
FEKA 600 M-NA - SV	103002784	1X220-240 V~	1	0,55	0,75	4,3	-	-
FEKA 600 T-NA - SV	103005824	3X400 V~	1	0,55	0,75	1,7	-	-

M - T = Available in single-phase (M) and three-phase (T) version

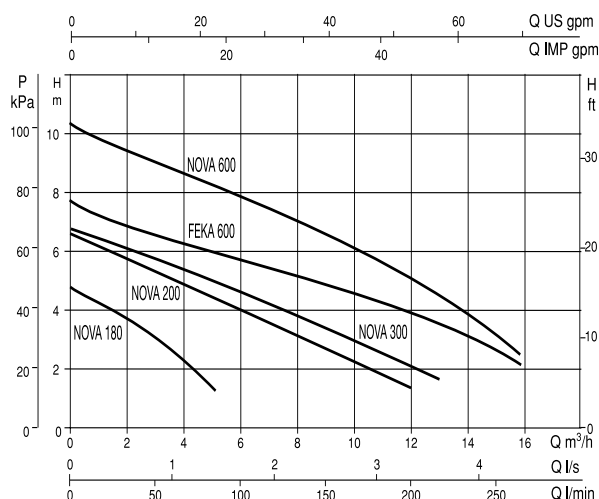

DIMENSIONS AND WEIGHTS

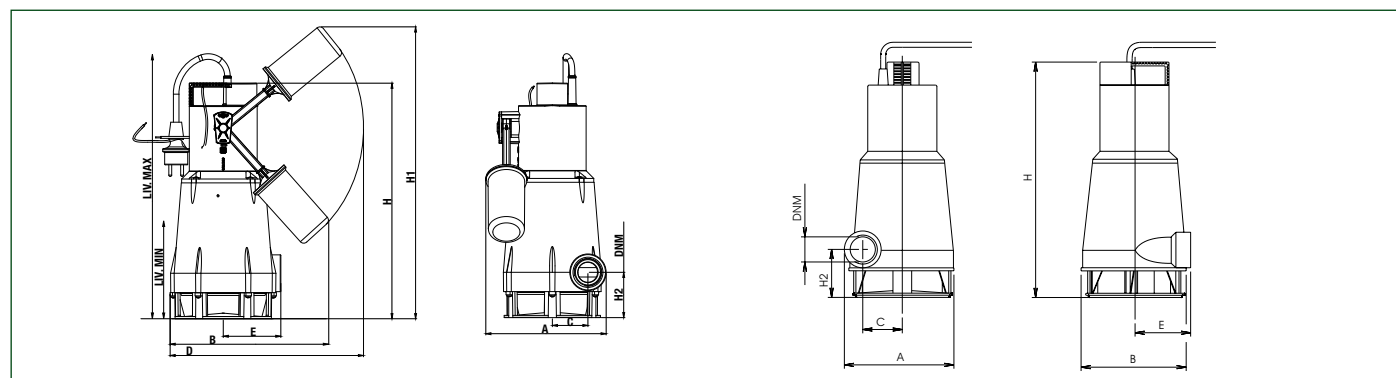

MODEL	A	B	C	D	E	H	H1	H2	LIV. MIN.	LIV. MAX.	DNM GAS	PACKAGING DIMENSIONS			CABLE	Q.TY X PALLET	WEIGHT KG
												L/A	L/B	H			
FEKA 600 M-A	193	235	56	296	90	368	443	73	190	190	1 1/4"	287	202	431	5 mt. H05	32	7
FEKA 600 (M-T)-NA	162	160	56	-	90	368	-	73	-	-	1 1/4"	287	202	431	10 mt. H05	32	6,7
FEKA 600 M-A SV *	193	235	56	296	90	368	443	73	190	190	1 1/4"	287	202	431	5 mt. H05	32	7
FEKA 600 (M-T)-NA SV *	162	160	56	-	90	368	-	73	-	-	1 1/4"	287	202	431	10 mt. H05	32	6,7

* With special stainless steel motor shaft.